

NEWALL

Kit Contents Lathe Bracket Kit Part # LBK03

This kit mounts two Microsyn / MHG Series Reader Heads.



294-22530
Angle - 3x3" (1)



294-22510
Flat Plate
Double Slotted (1)

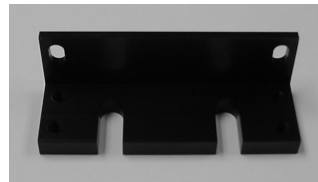

294-35260
Micro Angle (1)

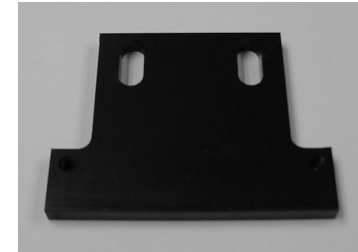

294-35270
Micro Plate (1)

600-65340
Single End Mount Kit (1)

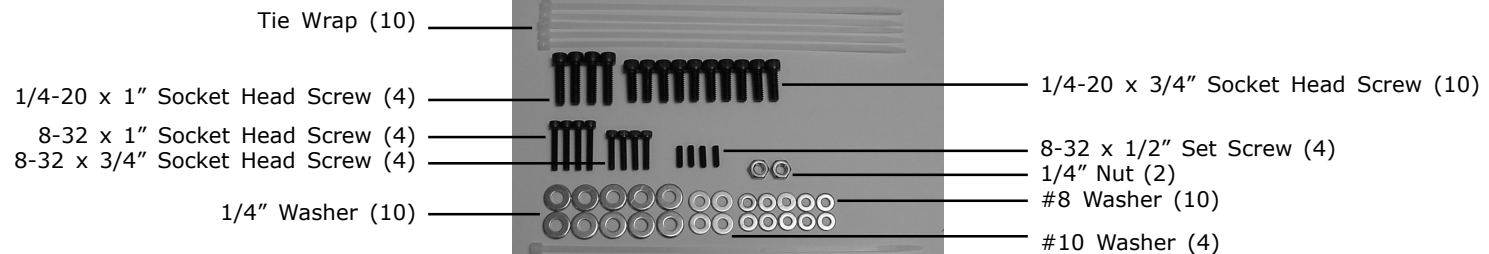
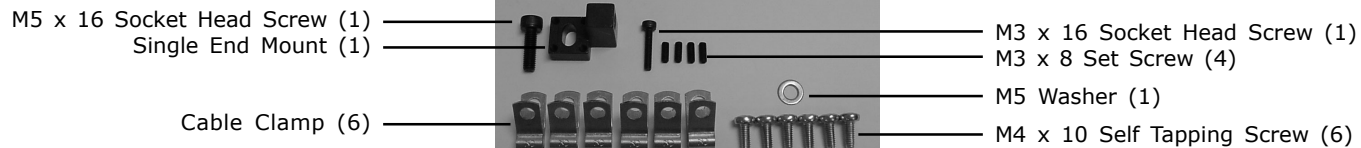

Some modification of bracketry may be necessary during installation.

NEWALL

Bracket Drawings Lathe Bracket Kit Part # LBK03

This kit mounts two Microsyn / MHG Series Reader Heads.

Part # 294-35260

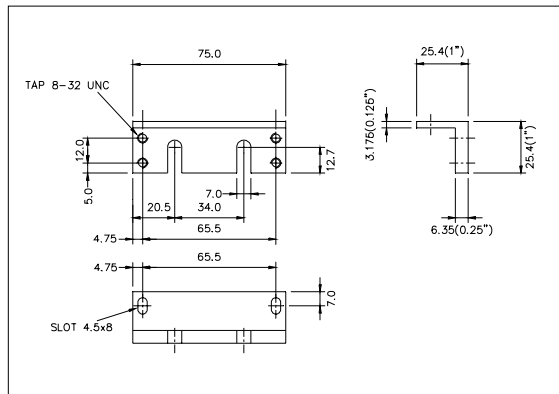

Part # 294-22510

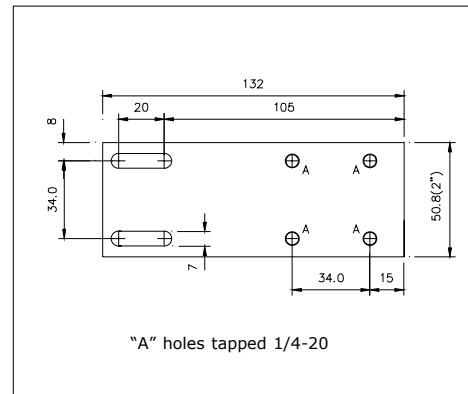

"A" holes tapped 1/4-20

Part # 294-35270

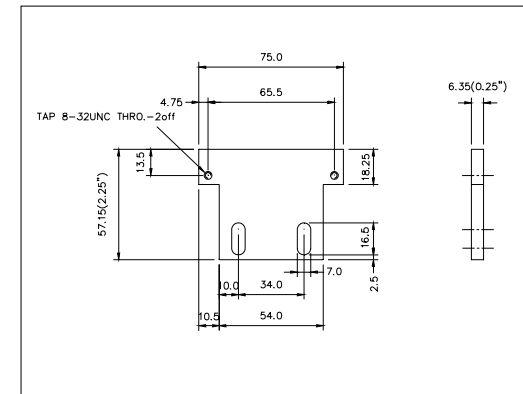

Part # 294-22530

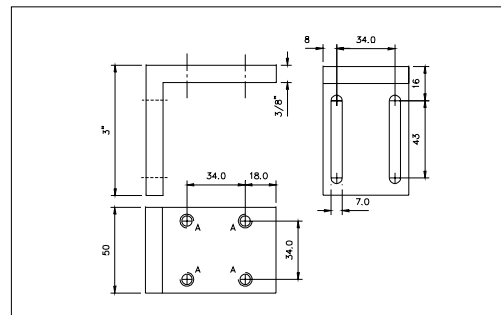

Single End Mount

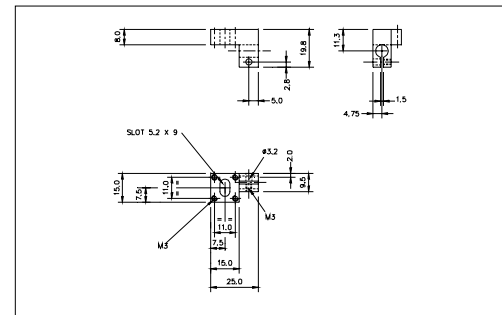

NEWALL

Installation Drawings Lathe Bracket Kit Part # LBK03

This kit mounts two Microsyn / MHG Series Reader Heads.

Cross Slide (X-axis)

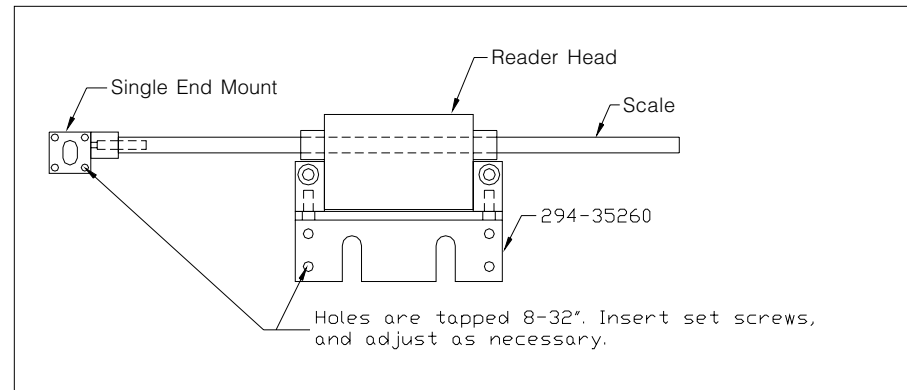

Longitudinal Axis (Z-axis) - Method #1

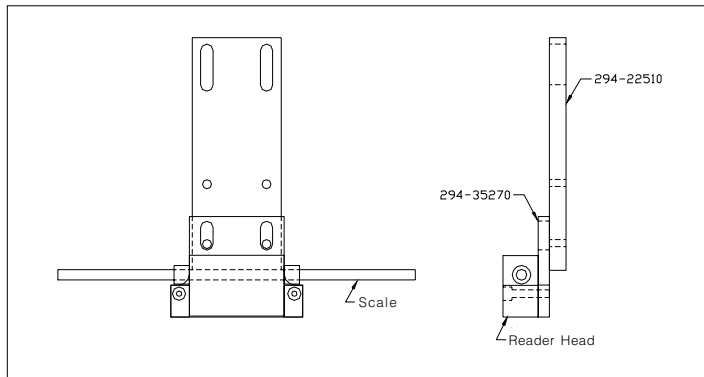

Longitudinal Axis (Z-axis) - Method #2

