

NEWALL

Kit Contents

Quill Kit - Metric

Part No: 600-65480

To mount 1 Microsyn or Microsyn-LT Scale <275mm Travel on the z axis (quill)

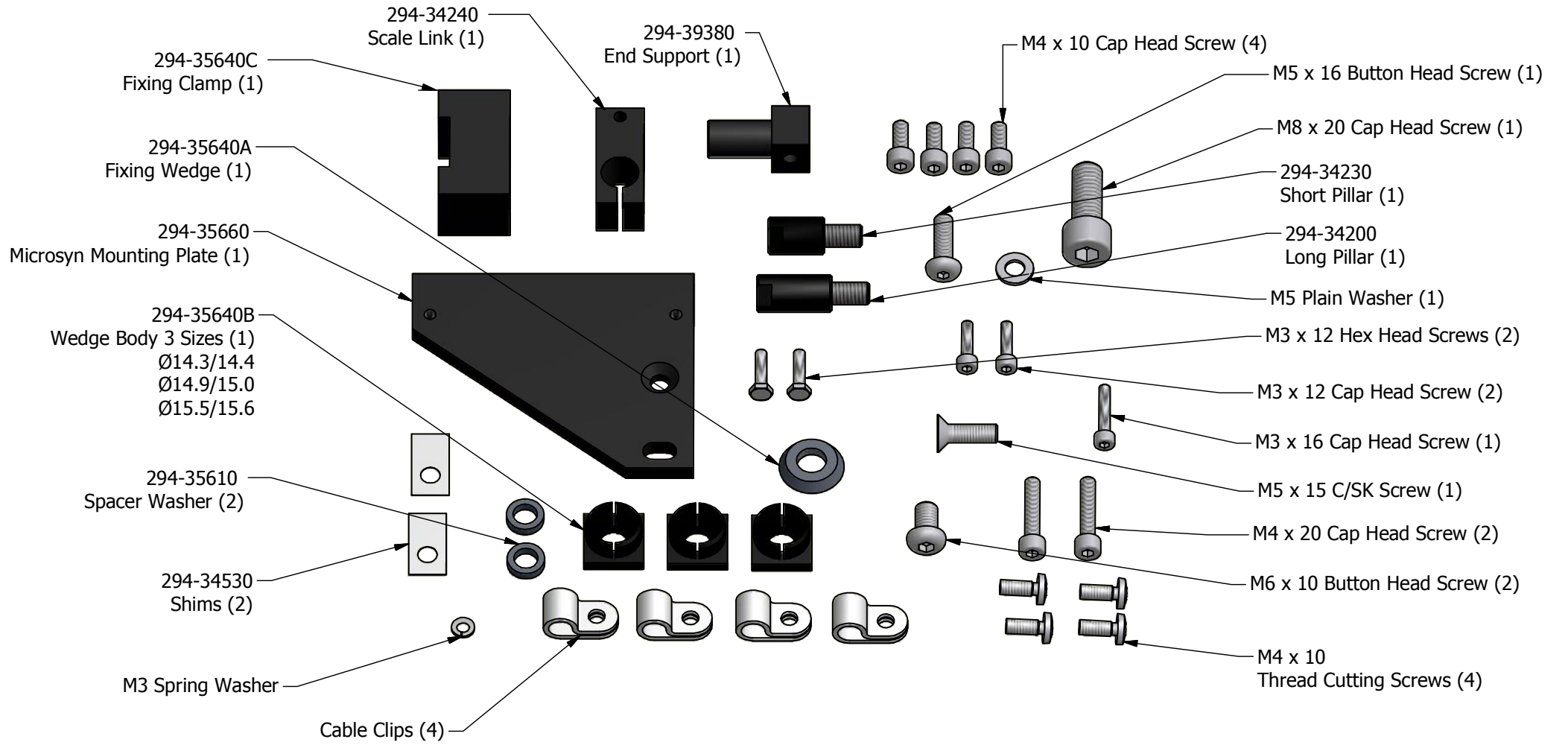

				TITLE 600-65480 Kit Contents and Installation Instructions		MATERIAL/FINISH N/A		SCALE N/A		UNLESS OTHERWISE STATED: - TOLERANCES: - 0 DECIMAL PLACES ± 0.5 1 DECIMAL PLACES ± 0.2 2 DECIMAL PLACES ± 0.1 DIMENSIONS ARE IN M.M ANGULAR ± 1°			
				DRAWN chris.wh DATE 07/05/2015		NEWALL England		SHEET 2 OF 2		DRAWING NUMBER 023-82180		REV. ISS. 0	
REV. ISS.	DATE	C.N.No	ALTERATION										

THIS DRAWING IS THE PROPERTY OF NEWALL MEASUREMENT SYSTEMS LTD. THE INFORMATION THEREON MAY NOT BE COPIED OR USED WITHOUT WRITTEN PERMISSION

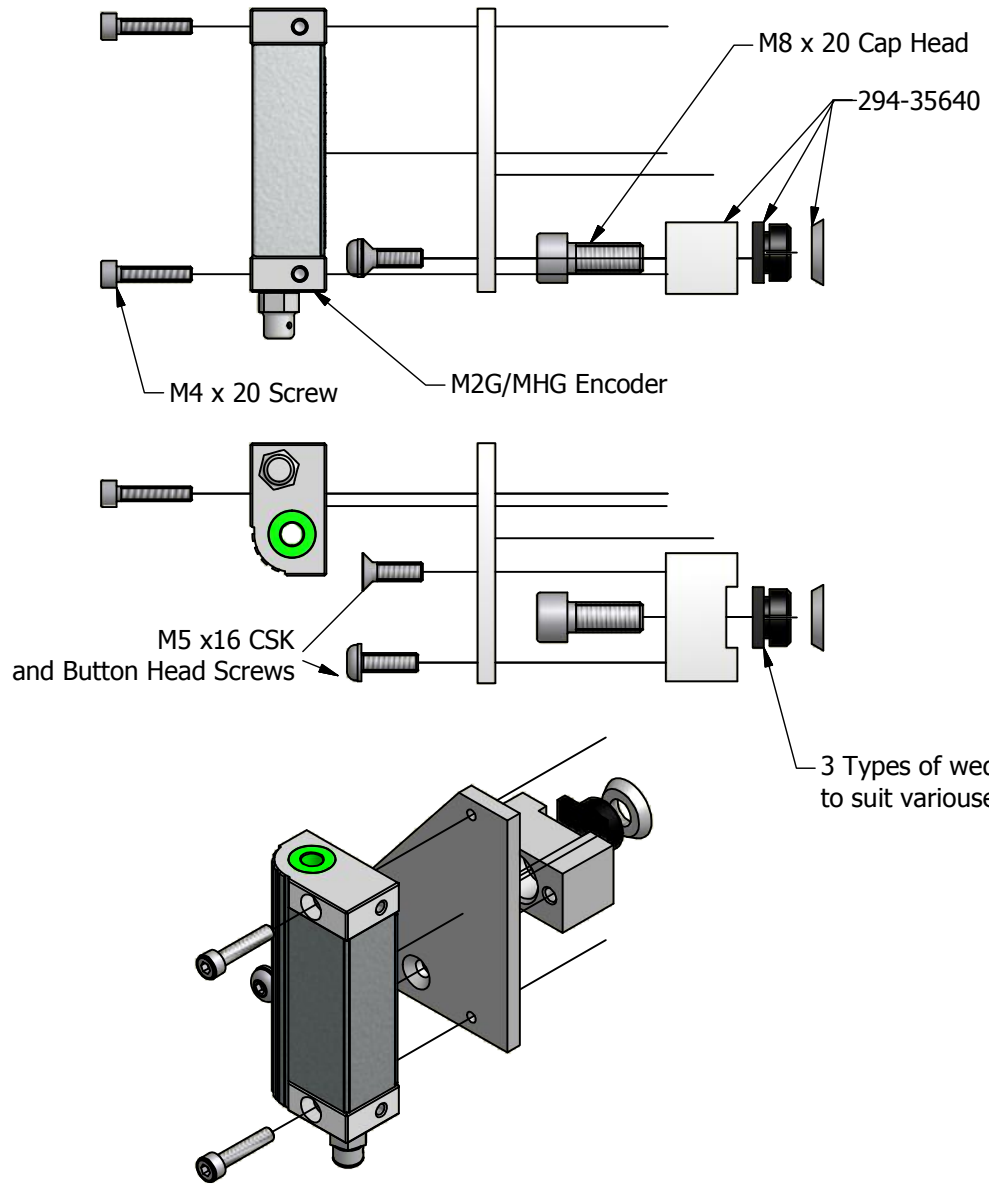

Note: Standard Newall tolerances apply - max travel of 275mm for single end mounting.

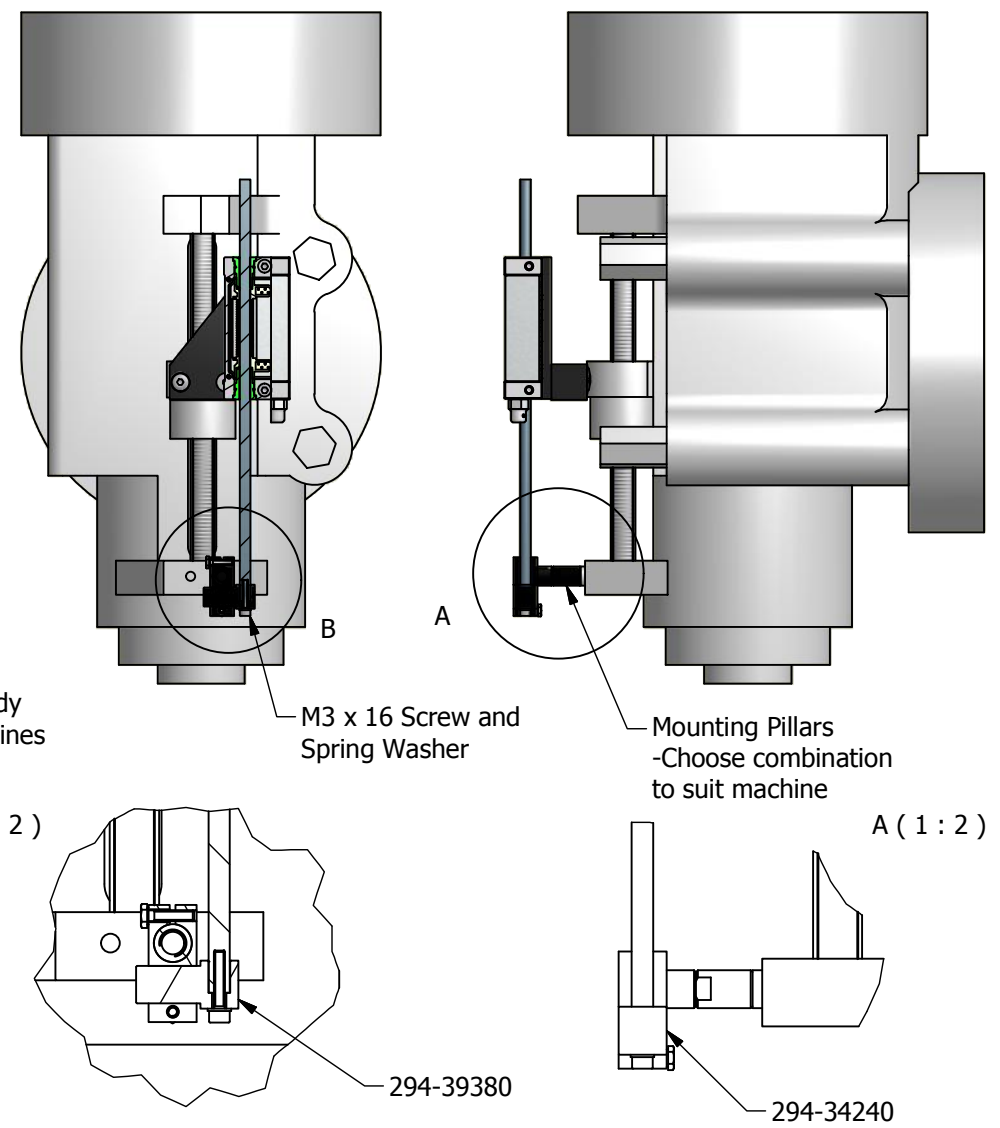

				TITLE Metric Quill Kit Installation Drawing		MATERIAL/FINISH N/A		SCALE NTS		UNLESS OTHERWISE STATED: - TOLERANCES: - 0 DECIMAL PLACES ± 0.5 1 DECIMAL PLACES ± 0.2 2 DECIMAL PLACES ± 0.1 ANGULAR ± 1'			
				DRAWN chris.wh		NEWALL England		SHEET 1 OF 2		DRAWING NUMBER 023-82180		REV. ISS. 0	
REV. ISS. DATE C.N.No ALTERATION				DATE 07/05/2015									