

SINGLE END SCALE MOUNTING
Left and right hand versions available.

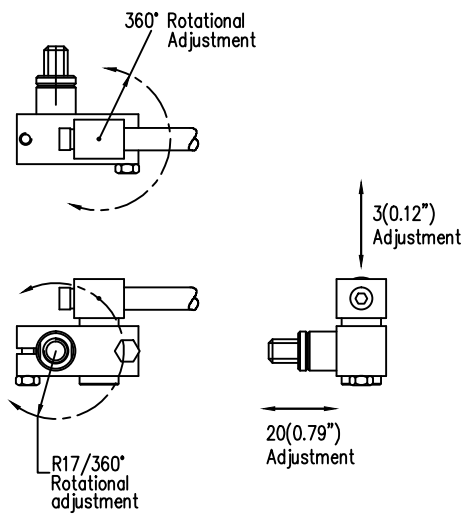

SCALE MOUNTING BRACKET ADJUSTMENT

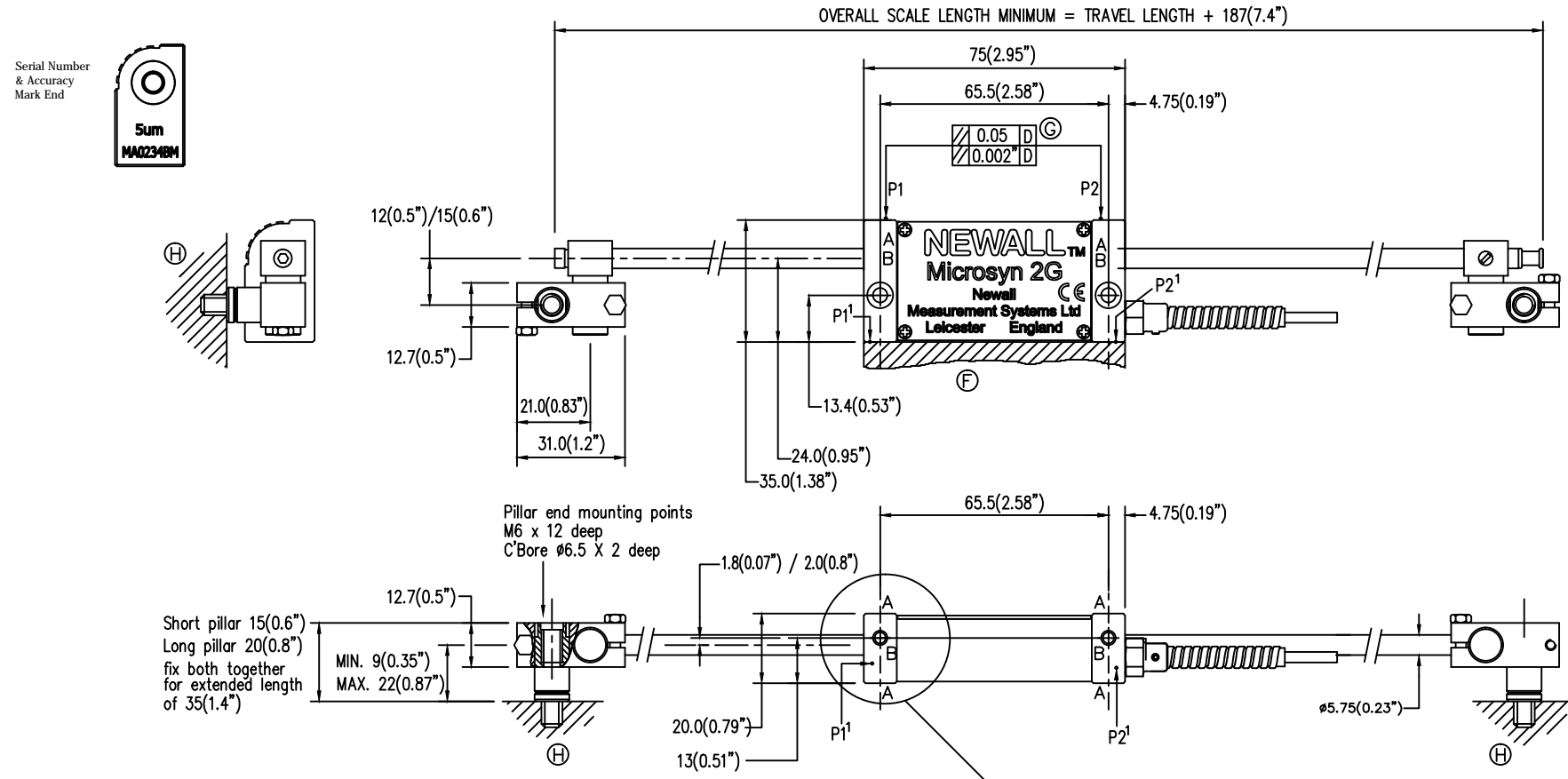
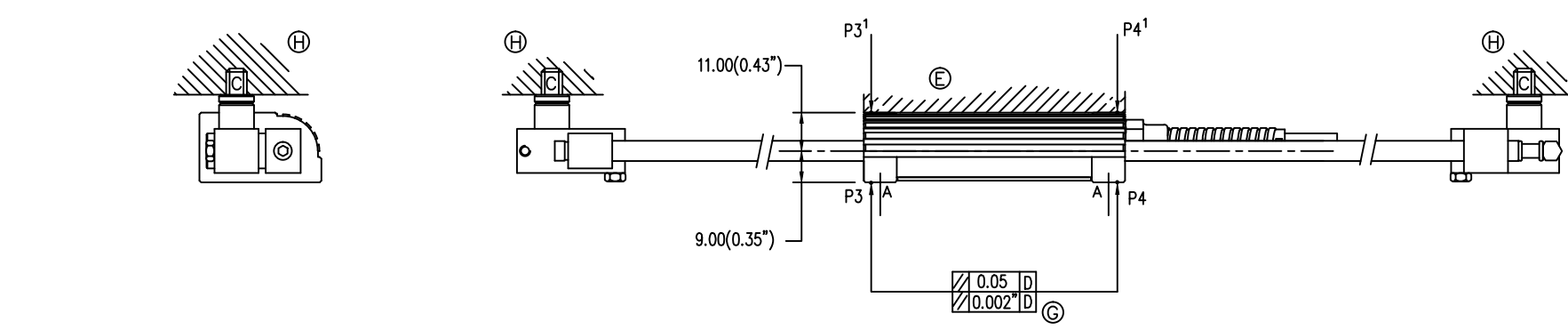

Mountings "A"
ø4.2 THRO' & C'BORE ø7.5 x 4.5 DEEP
each side of housing to accept
M4 cap head screws.

- A - Encoder head mounting points 2off for M4 cap head screws (clearance holes through).
- B - Encoder head mounting points 2off for M4 screws (thread depth 8).
- C - Scale pillar mounting studs M6 x 10 (use spacer washer as required).
- D - Machine Guideway.
- E/F - Encoder head mounting faces.
- G - Indicating parallel alignment required between encoder head and axis travel.
- H - Scale end mounting points to machine bed.
- P - Installation alignment points.

DIMENSIONS - mm (ins")
FOR FURTHER INFORMATION REFER TO INSTALLATION MANUAL

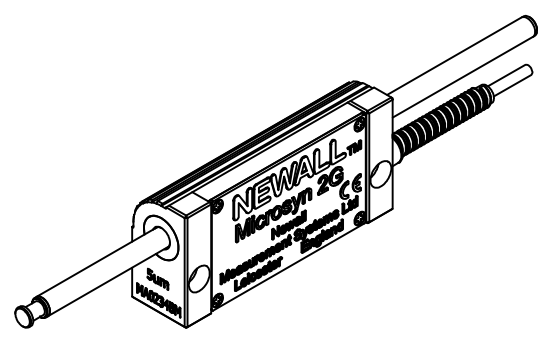

REV. ISS. DATE C.N.No. ALTERATION				TITLE SALES LITERATURE DRAWINGS for MICROSYN M2G				MATERIAL/ FINISH		SCALE 1=1		UNLESS OTHERWISE STATED :- DIMENSIONS ARE IN MM.		TOLERANCES:- 0 DECIMAL PLACES ±0.5 1 DECIMAL PLACE ±0.2 2 DECIMAL PLACES ±0.1 ANGULAR ±1'	
2	27-11-13	ECN9370	IMPERIAL FIXINGS REMOVED, NOW METRIC ONLY	CWH											
1	27-5-10	Pre-prod	DRAWING REVISED TO SHOW MICROSYN M2G	JFD											
REV. ISS. DATE C.N.No. ALTERATION				REV. ISS. DATE C.N.No. ALTERATION				DRAWN J.DRIVER 18-08-04		SHEET 1 OF 1		DRAWING NUMBER 316-82010		REV. ISS. 2	
								APPROVED		Leicester NEWALL England		THIS DRAWING IS THE PROPERTY OF NEWALL MEASUREMENT SYSTEMS LIMITED. THE INFORMATION THEREON MAY NOT BE COPIED OR USED WITHOUT WRITTEN PERMISSION			